

Location:



Ductile Iron Wave Grate to suit 12" clear opening channels



Specification: T300-PGC-4-WVY ductile iron grates are independently certified to meet Load Class C tested in accordance with EN 1433 56,200 lbs. 250kN. The grate length is 19.69" (.5 m). The grates utilize the patented "Clipfix" grate locking mechanism. The system (channel and grate) provides longitudinal shift protection.

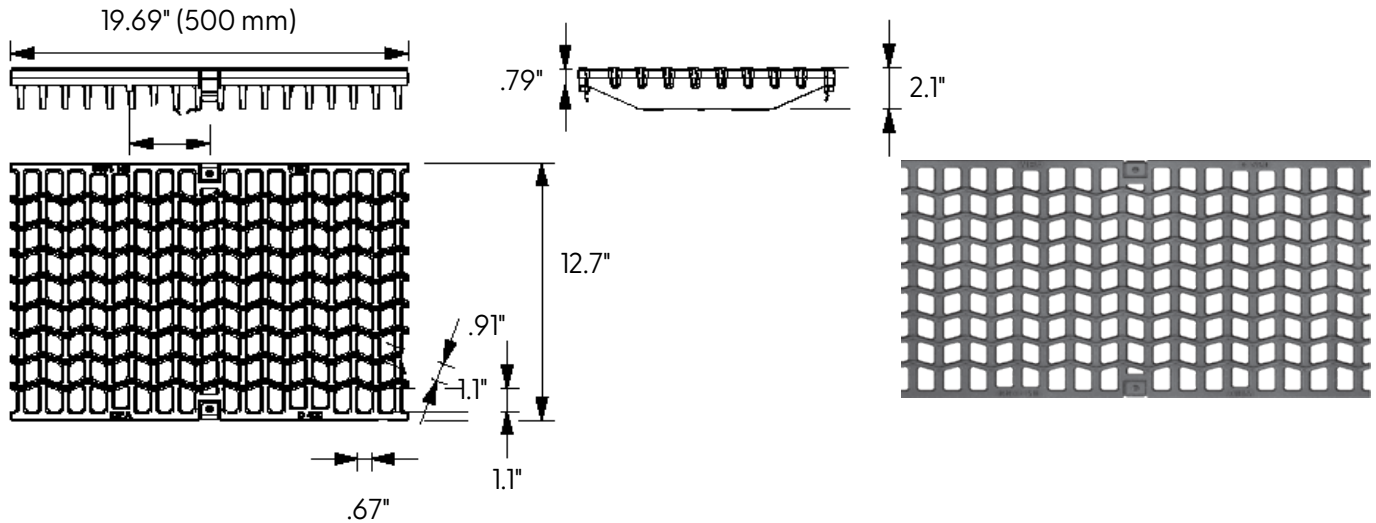

CLIPFIX ADVANTAGE

The MEA polymer concrete and GRP channels are designed for our universal CLIPFIX grate locking mechanism. The system (channel and grate) provides longitudinal shift protection.

LOAD CLASS C



EN 1433 - 56,200 LBS.,
250kN, 1160 PSI

| GRATE MODEL NUMBER | LENGTH | USED WITH |
|--------------------|-----------------|------------------------|
| T300-PGC-4-WVY | 19.69" (500 mm) | T1800 Concrete Channel |
| TP300-PGC-4-WVY | 19.69" (500 mm) | T3000 Plastic Channel |

Supplied By:



877-903-7246

www.trenchdrainsupply.com

| | |
|--------------------|--------------------------|
| Job Name: _____ | Page No: _____ |
| Section No: _____ | Contractor: _____ |
| Schedule No: _____ | Purchase Order No: _____ |