

Location:



Ductile Iron Heelproof Slotted Grate to suit 12" clear opening channels



Specification: T300-PGC-4-HP ductile iron heelproof slotted grates are independently certified to meet Load Class C tested in accordance with EN 1433 56,200 lbs. 250kN. The grate length is 19.69" (.5 m). The grates utilize the patented "Clipfix" grate locking mechanism. The system (channel and grate) provides longitudinal shift protection.

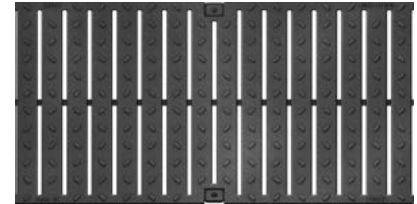
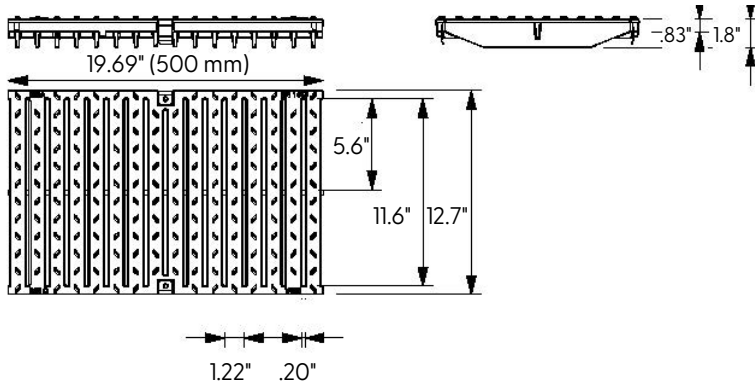

CLIPFIX ADVANTAGE

The MEA polymer concrete and GRP channels are designed for our universal CLIPFIX grate locking mechanism. The system (channel and grate) provides longitudinal shift protection.

LOAD CLASS C



EN 1433 - 56,200 LBS.,
250kN, 1160 PSI

Compliance



HEELPROOF

GRATE MODEL NUMBER	LENGTH	USED WITH
T300-PGC-4-HP	19.69" (500 mm)	T1800 Concrete Channel
TP300-PGC-4-HP	19.69" (500 mm)	T3000 Plastic Channel

Supplied By:



Job Name: _____	Page No: _____
Section No: _____	Contractor: _____
Schedule No: _____	Purchase Order No: _____

CALIFORNIA PROPOSITION 65 WARNING. This product contains chemicals known to the State of California to cause cancer and birth defects or other reproductive harm.