

Location:



## Stainless Steel Mesh Gate to suit 12" clear opening channels



**Specification:** T300-PGC-3-SM stainless steel mesh gates are independently certified to meet Load Class C tested in accordance with EN 1433 (56,200 lbs (250kN)). The grate length is 39.37" (1 m). The grates utilize the patented "Clipfix" grate locking mechanism. The system (channel and grate) provides longitudinal shift protection. Optional .5 m grates are also available in Load Class C (Part # T300-PGC-3-SM-500).

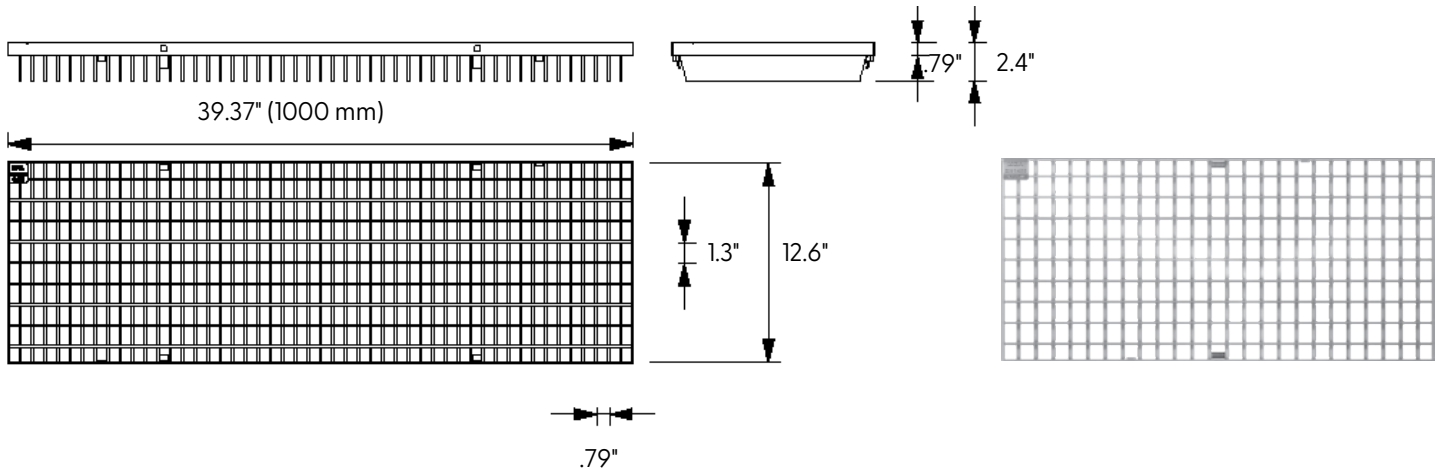

LOAD CLASS C



EN 1433 - 56,200 LBS.,  
250kN, 1160 PSI

Compliance



ADA

### CLIPFIX ADVANTAGE

The MEA polymer concrete and GRP channels are designed for our universal CLIPFIX grate locking mechanism. The system (channel and grate) provides longitudinal shift protection.

GRATE MODEL NUMBER	LENGTH	USED WITH
T300-PGC-3-SM	39.37" (1000 mm)	T1800 Concrete Channel
T300-PGC-3-SM-500	19.69" (500 mm)	T1800 Concrete Channel
TP300-PGC-3-SM	39.37" (1000 mm)	T3000 Plastic Channel
TP300-PGC-3-SM-500	19.69" (500 mm)	T3000 Plastic Channel

Supplied By:

**TRENCHDRAIN  
SUPPLY**

877-903-7246

www.trenchdrainsupply.com

Job Name: \_\_\_\_\_

Page No: \_\_\_\_\_

Section No: \_\_\_\_\_

Contractor: \_\_\_\_\_

Schedule No: \_\_\_\_\_

Purchase Order No: \_\_\_\_\_