

Location:



Galvanized Steel Paverslot Maintenance Unit Grate to suit 4" clear opening channels



Specification: T100-PGC-13-SD-MU-500 galvanized maintenance unit paverslot grates are independently certified to meet Load Class C tested in accordance with EN1433 (56,200 lbs. 250kN). The grate length is 19.69" (.5 m). The grates utilize the patented "Clipfix" grate locking mechanism. The system (channel and grate) provides longitudinal shift protection.

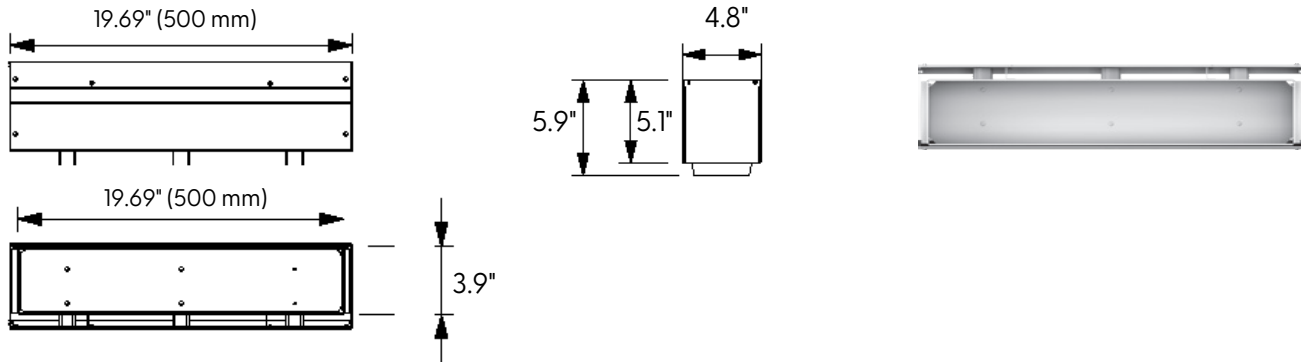

LOAD CLASS C



EN 1433 - 56,200 LBS.,
250kN, 1,160 PSI

Compliance



ADA



HEELPROOF

CLIPFIX ADVANTAGE

The MEA polymer concrete and GRP channels are designed for our universal CLIPFIX grate locking mechanism. The system (channel and grate) provides longitudinal shift protection.

GRATE MODEL NUMBER	LENGTH	USED WITH
T100-PGC-13-SD-MU-500	19.69" (500 mm)	T1500 Concrete Channel
TP100-PGC-13-SD-MU-500	19.69" (500 mm)	T1400 Plastic Channel or T1330 Aluminum Channel

Supplied By:



Job Name: _____	Page No: _____
Section No: _____	Contractor: _____
Schedule No: _____	Purchase Order No: _____

CALIFORNIA PROPOSITION 65 WARNING. This product contains chemicals known to the State of California to cause cancer and birth defects or other reproductive harm.